

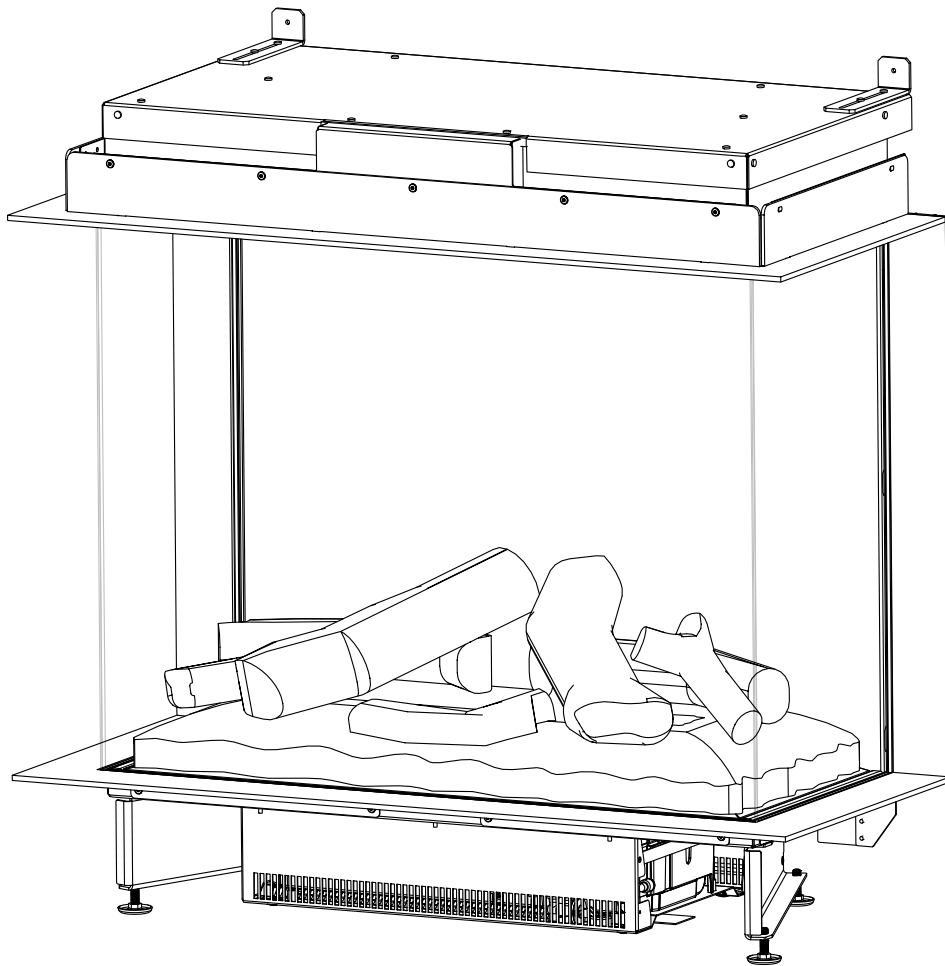

FEF3226L1  
FEF3226L2L  
FEF3226L2R  
FEF3226L3

## e-Matrix Replacement Parts List



**NOTE:** A T20 Torx driver will be needed to perform some of the service listed in this manual. See relevant section for a list of tools needed.

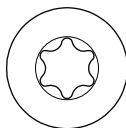

**IMPORTANT SAFETY INFORMATION:** Always read this manual first before attempting to service this cassette. For your safety, always comply with all warnings and safety instructions contained in this manual to prevent personal injury or property damage.

# Table of Contents

---

**Exploded Parts Diagram** ..... **3**

Replacement Parts - FEF3226L1 ..... 3

Replacement Parts - FEF3226L2L ..... 4

Replacement Parts - FEF3226L2R ..... 5

Replacement Parts - FEF3226L3 ..... 6

**Wiring Diagrams** ..... **7**

Fireplace (Engine) Wiring Diagram ..... 7

Control Box Wiring Diagram ..... 8

Extractor Fan Wiring Diagram ..... 8

# Exploded Parts Diagram - FEF3226L1

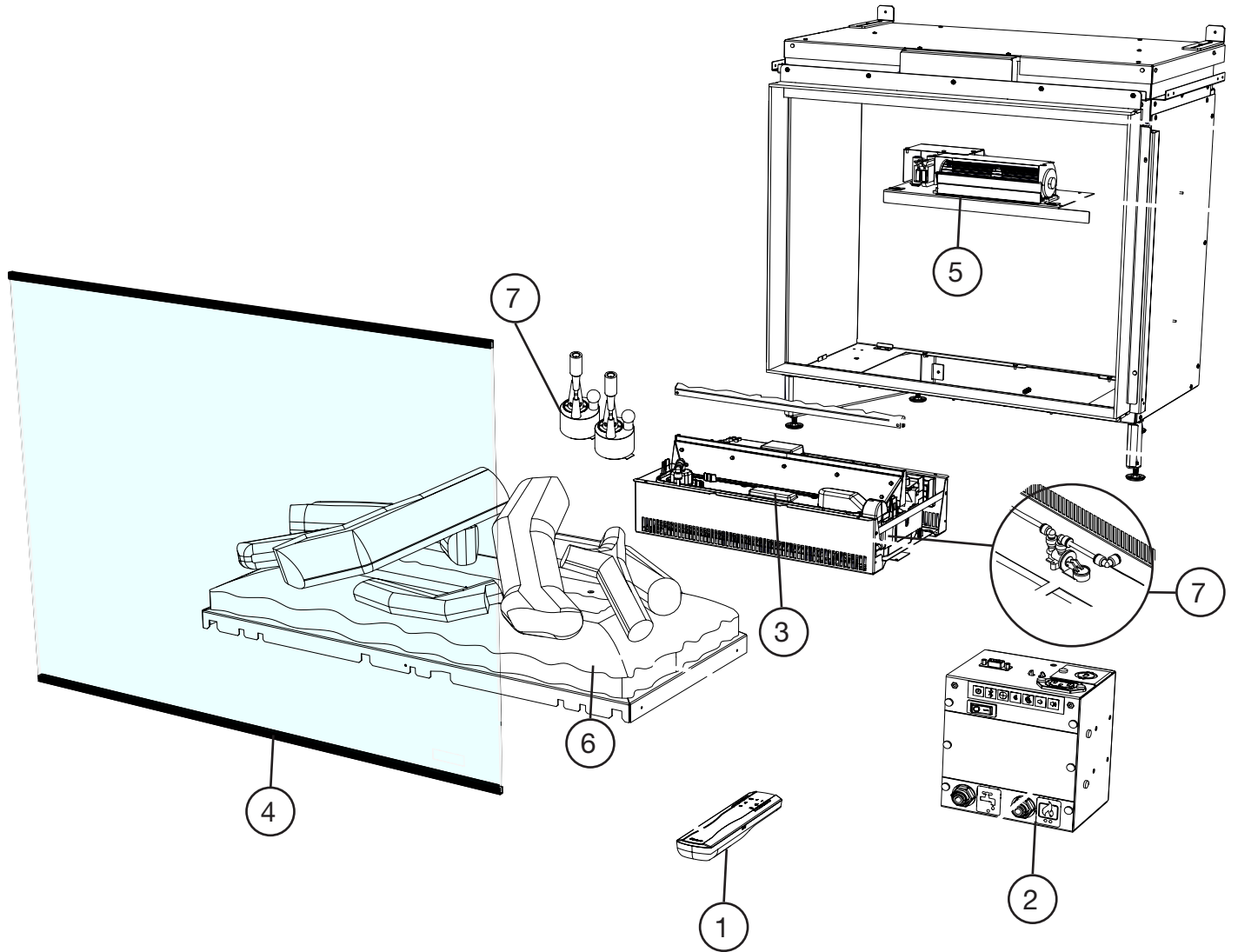

## Replacement Parts - FEF3226L1

1. Absorption Valve . . . . .	X-9602570100RP	12. Connection Wire . . . . .	X-4100380100RP
2. Bluetooth Tether . . . . .	500002709	13. Extractor Fan . . . . .	X-2000530100RP
3. Remote Control . . . . .	500002673	14. Fuel Bed . . . . .	X-0442790100RP
4. Plumbing Accessory Pack (includes tubing, clips and piercing valve). . . . .	X-9602500100RP	Engine Components	
5. Terminal Block Set . . . . .	X-9601260200RP	15. Transducer (2) . . . . .	X-9601210100RP
6. Top Cover Assembly . . . . .	X-9601220200RP		
7. Control Box Assembly . . . . .	X-6910190100RP		
8. Engine . . . . .	500002710		
9. Front Glass . . . . .	X-5903300100RP		
10. Glass sides . . . . .	X-5903290100RP		
11. Fan Wire Extension. . . . .	X-4100390100RP		

# Exploded Parts Diagram - FEF3226L2L

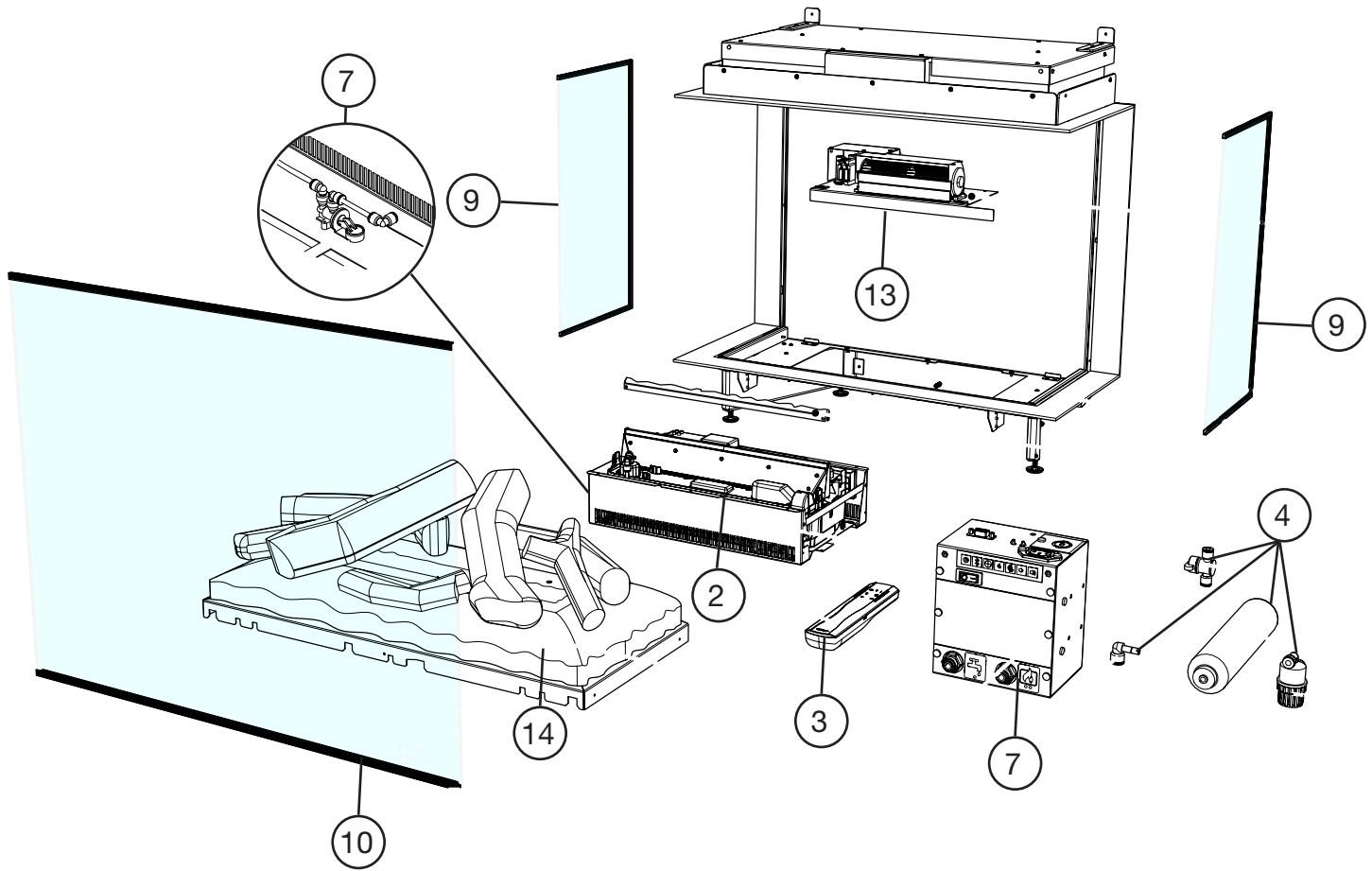

## Replacement Parts - FEF3226L2L

1. Absorption Valve . . . . .	X-9602570100RP	9. Glass sides . . . . .	X-5903290100RP
2. Bluetooth Tether . . . . .	500002709	10. Front glass . . . . .	X-5903280100RP
3. Remote Control . . . . .	500002673	11. Fan Wire Extension. . . . .	X-4100390100RP
4. Plumbing Accessory Pack (includes tubing, clips and piercing valve). . . . .	X-9602500100RP	12. Connection Wire . . . . .	X-4100380100RP
5. Terminal Block Set . . . . .	X-9601260200RP	13. Extractor Fan . . . . .	X-2000530100RP
6. Top Cover Assembly . . . . .	X-9601220200RP	14. Fuel Bed . . . . .	X-0442790100RP
7. Control Box Assembly . . . . .	X-6910190100RP	Engine Components	
8. Engine . . . . .	500002710	15. Transducer (2) . . . . .	X-9601210100RP4

# Exploded Parts Diagram - FEF3226L2R

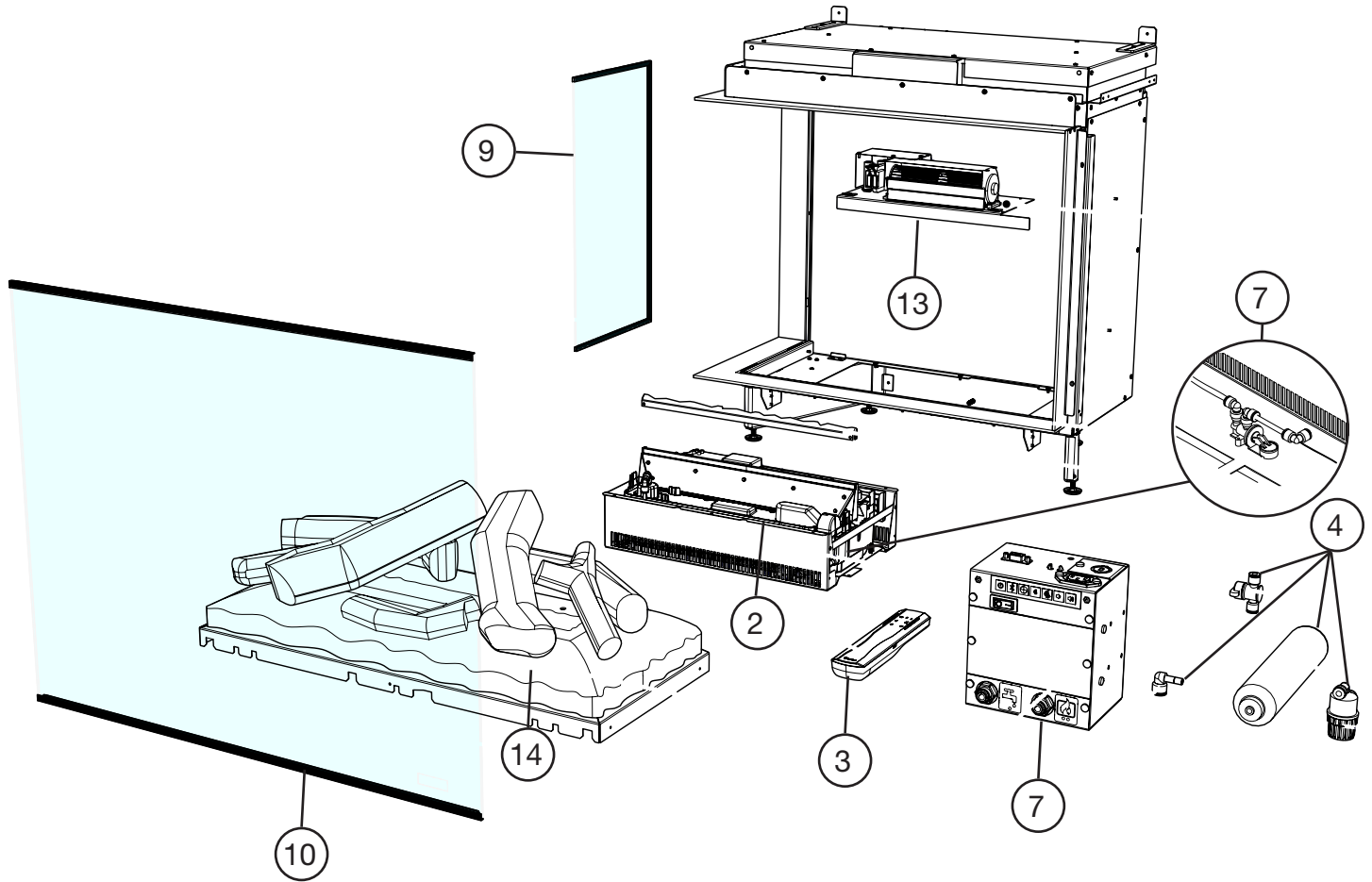

## Replacement Parts - FEF3226L2R

1. Absorption Valve . . . . .	X-9602570100RP	13. Extractor Fan . . . . .	X-2000530100RP
2. Bluetooth Tether . . . . .	500002709	14. Fuel Bed . . . . .	X-0442790100RP
3. Remote Control . . . . .	500002673	Engine Components	
4. Plumbing Accessory Pack (includes tubing, clips and-piercing valve). . . . .	X-9602500100RP	15. Transducer (2) . . . . .	X-9601210100RP
5. Terminal Block Set . . . . .	X-9601260200RP		
6. Top Cover Assembly . . . . .	X-9601220200RP		
7. Control Box Assembly . . . . .	X-6910190100RP		
8. Engine . . . . .	500002710		
9. Glass sides . . . . .	X-5903290100RP		
10. Front glass . . . . .	X-5903280100RP		
11. Fan Wire Extension. . . . .	X-4100390100RP		
12. Connection Wire . . . . .	X-4100380100RP		

# Exploded Parts Diagram - FEF3226L3

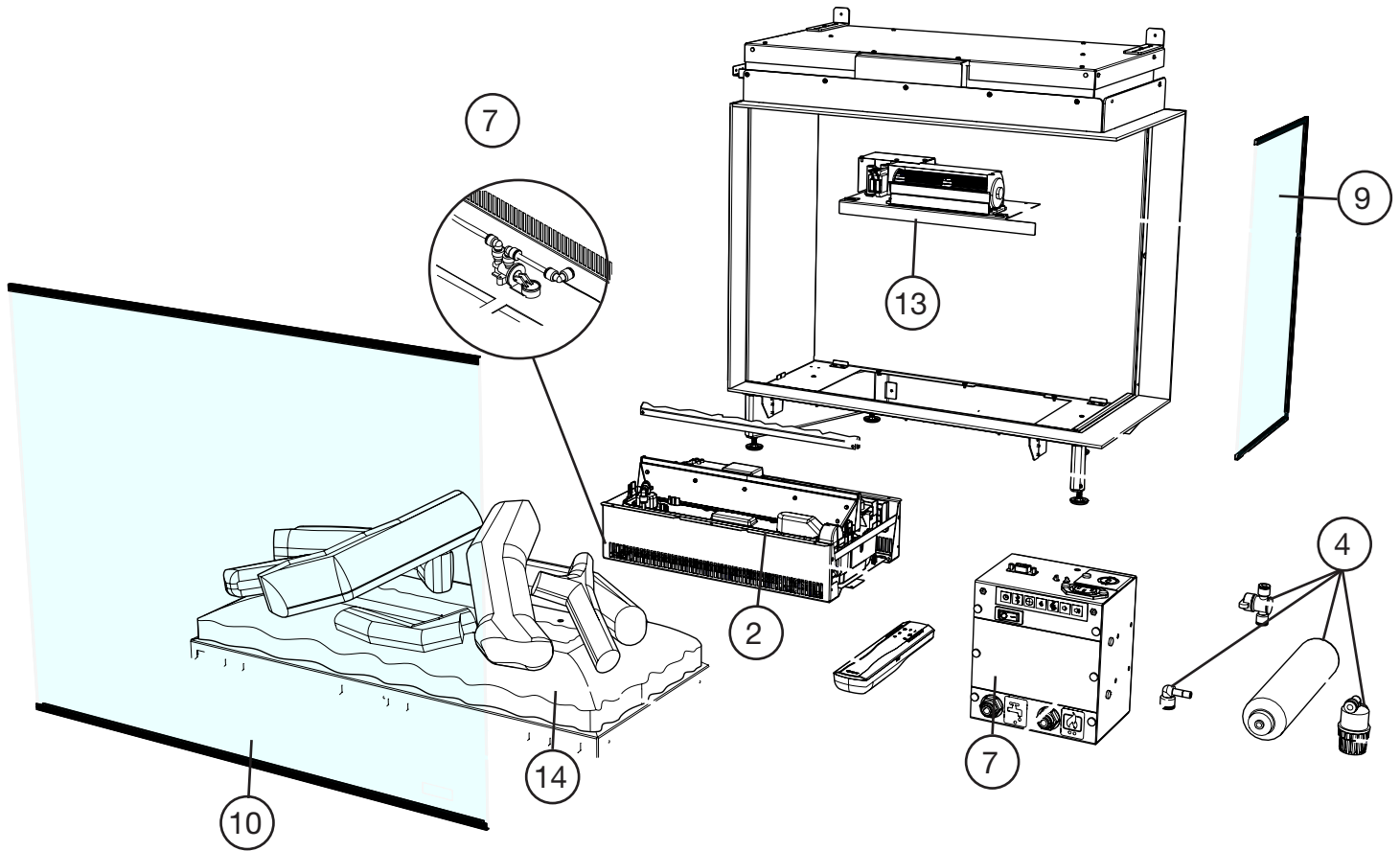

## Replacement Parts - FEF3226L3

1. Absorption Valve . . . . .	X-9602570100RP	12. Connection Wire . . . . .	X-4100380100RP
2. Bluetooth Tether . . . . .	500002709	13. Extractor Fan . . . . .	X-2000530100RP
3. Remote Control . . . . .	500002673	14. Fuel Bed . . . . .	X-0442790100RP
4. Plumbing Accessory Pack (includes tubing, clips and piercing valve). . . . .	X-9602500100RP	15. Engine Components	
5. Terminal Block Set . . . . .	X-9601260200RP	16. Transducer (2) . . . . .	X-9601210100RP
6. Top Cover Assembly . . . . .	X-9601220200RP		
7. Control Box Assembly . . . . .	X-6910190100RP		
8. Engine . . . . .	500002710		
9. Glass sides . . . . .	X-5903290100RP		
10. Front glass . . . . .	X-5903280100RP		
11. Fan Wire Extension. . . . .	X-4100390100RP		

# Fireplace (Engine) Wiring Diagram

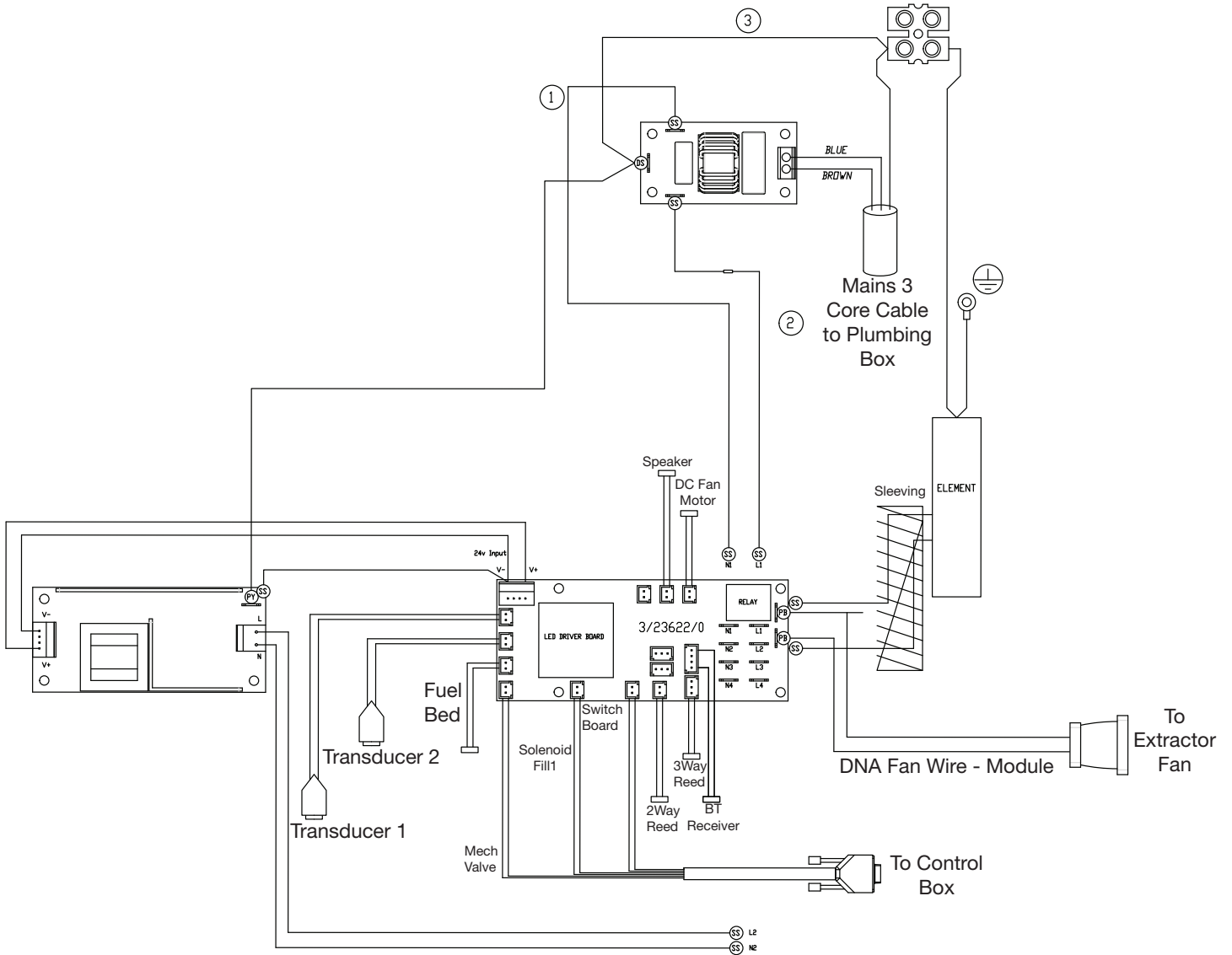

# Control Box Wiring Diagram

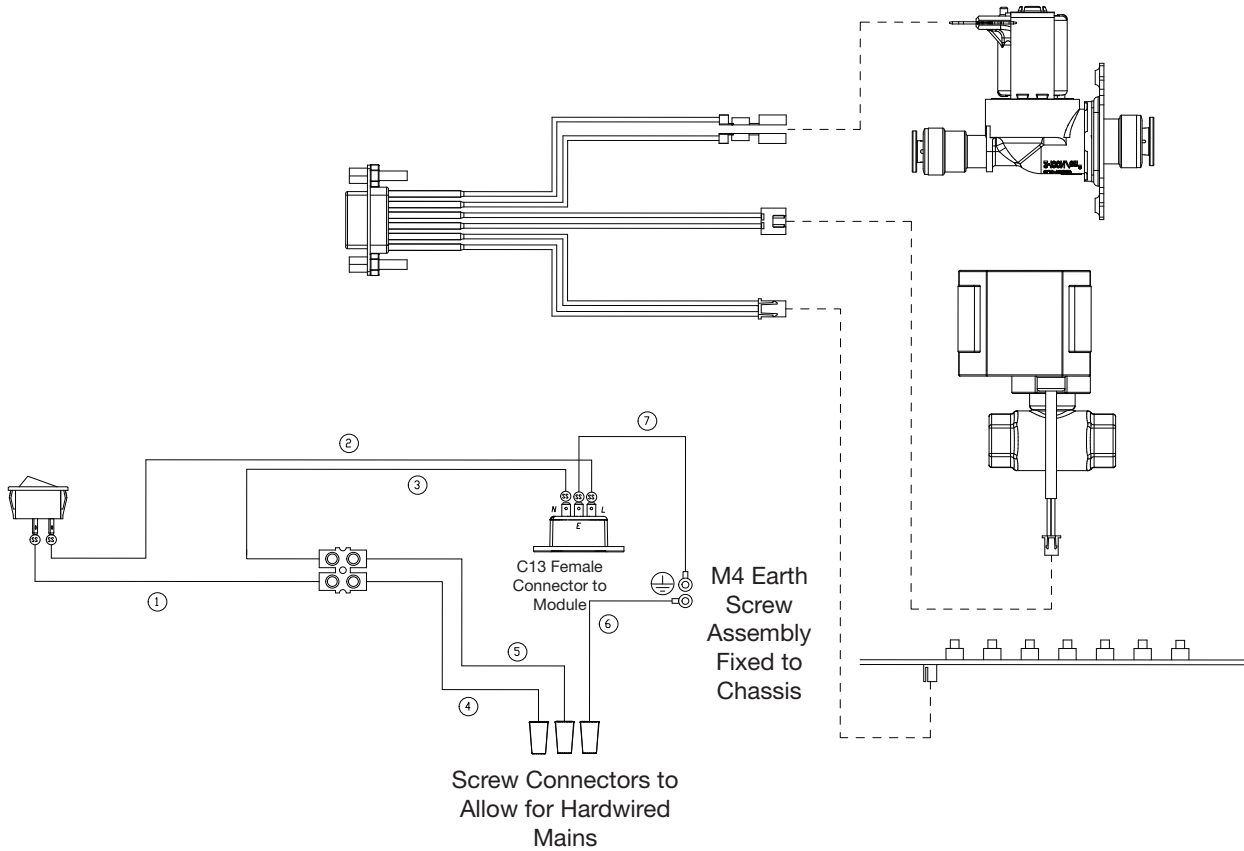

# Extractor Fan Wiring Diagram

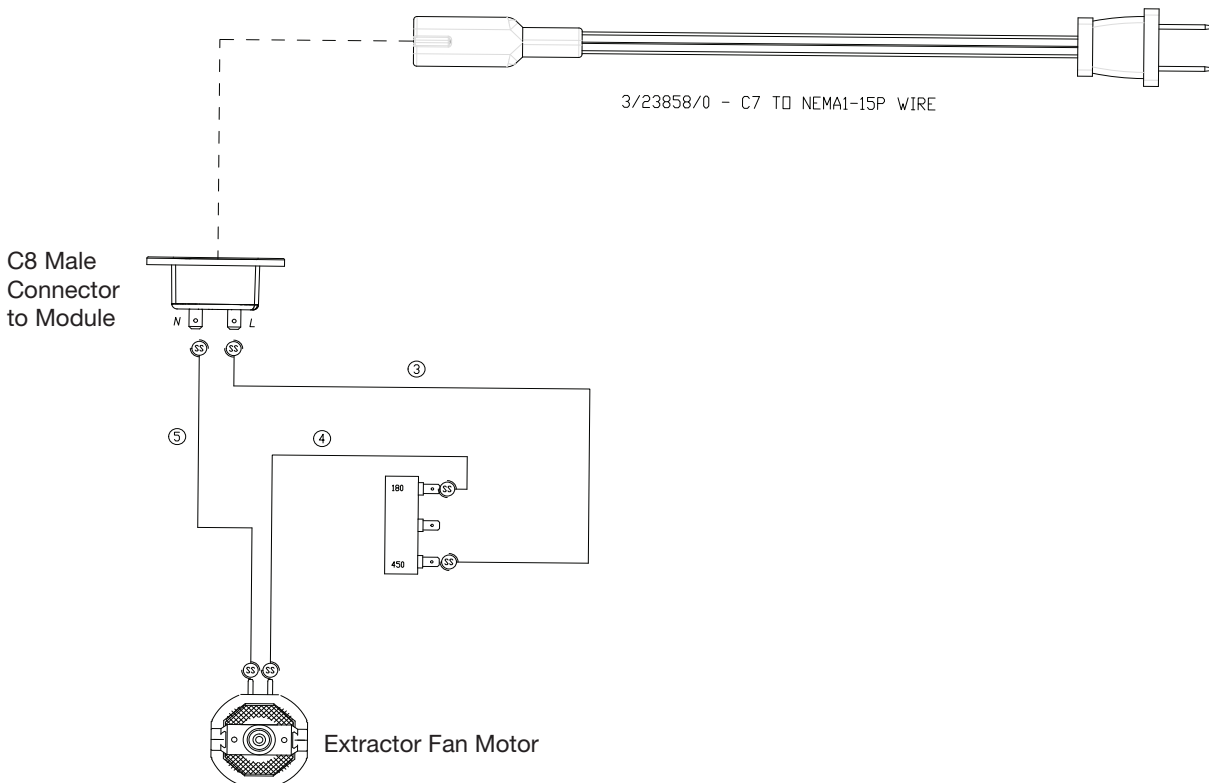





1-888-346-7539 | [www.faber.glendimplexamericas.com](http://www.faber.glendimplexamericas.com)

In keeping with our policy of continuous product improvements, we reserve the right to make changes without notice.

© 2023 Glen Dimplex Americas

